

PLEASE NOTE:

OVERALL HOISTWAY LENGTH AND WIDTH DIMENSIONS ARE FROM DRYWALL TO DRYWALL (WHERE APPLICABLE)

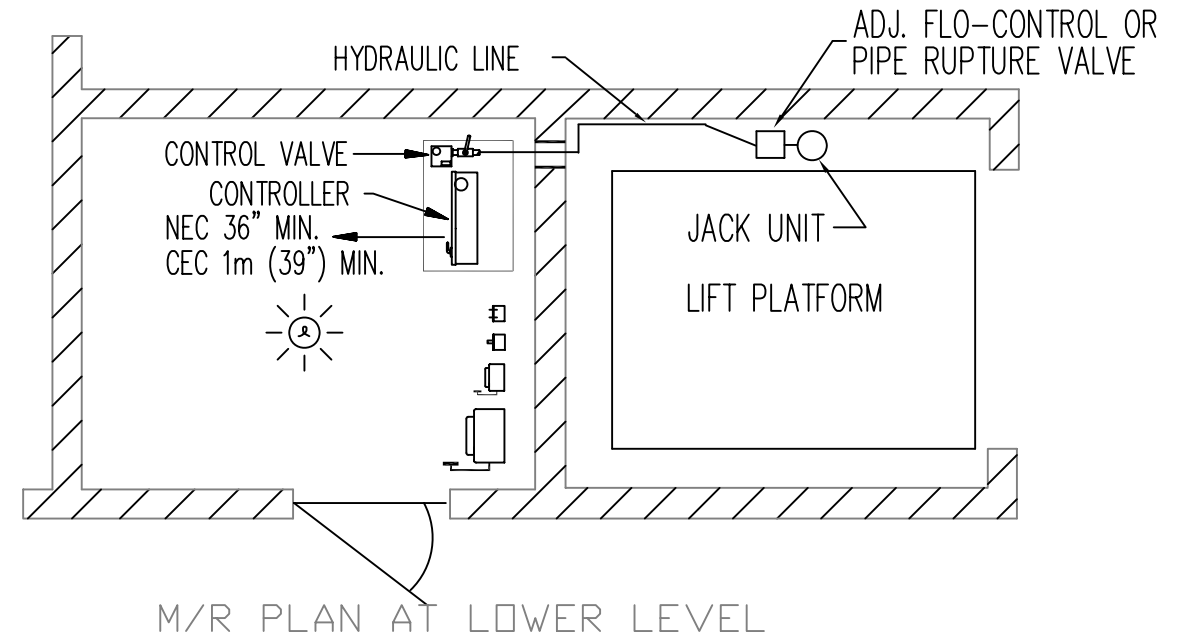
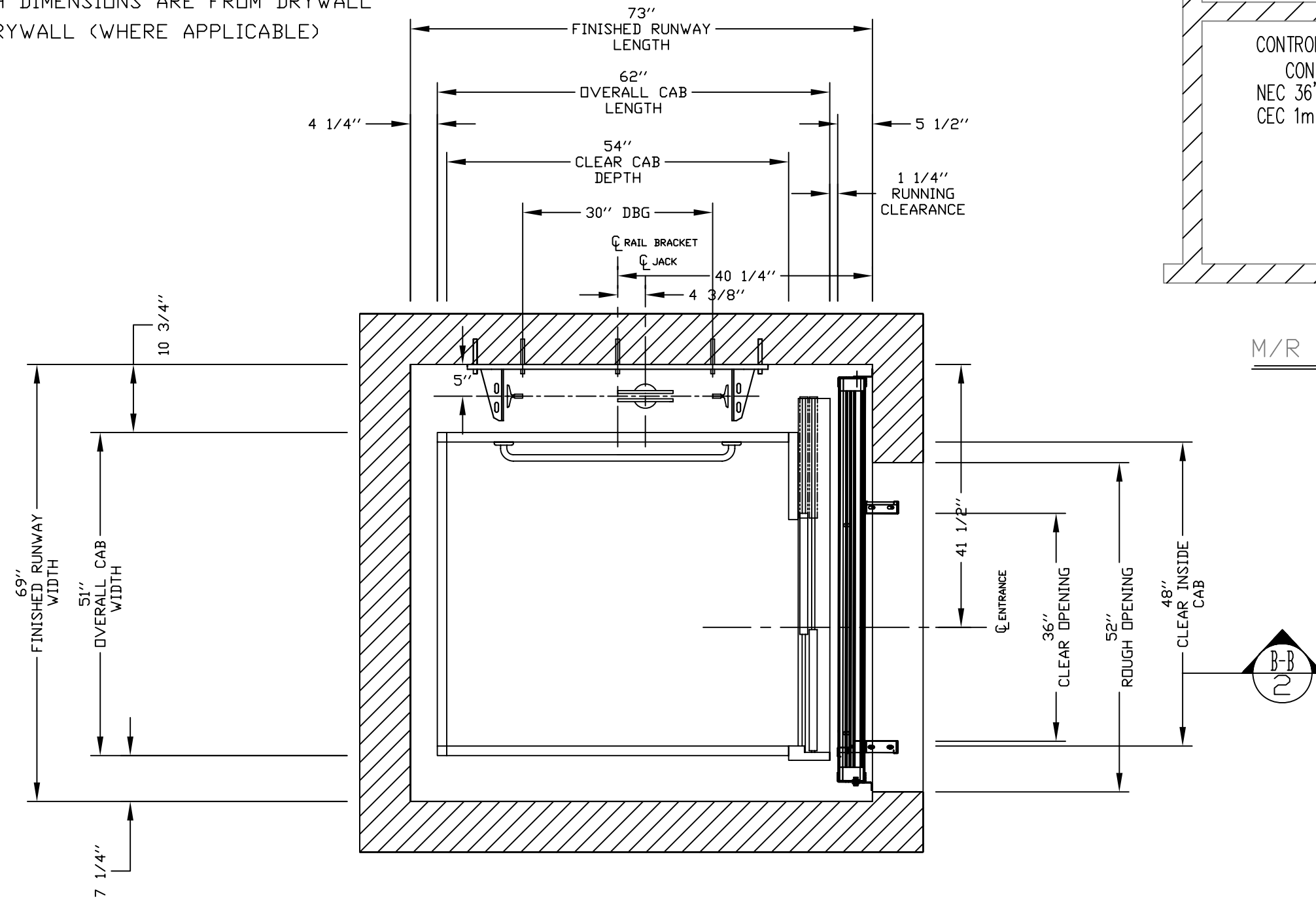

PRELIMINARY DRAWING ONLY  
DRAWING APPROVAL:

THIS DRAWING REFLECTS OUR INTERPRETATION OF THE INFORMATION PROVIDED BY THE DEALER ON THE ORDER FORM. THIS INFORMATION IS THE DEALER'S RESPONSIBILITY, AND IS THE BASIS FROM WHICH THIS LIFT IS DESIGNED AND MANUFACTURED. PLEASE INDICATE THE REQUESTED ACTION BY CHECKING ONE OF THE FOLLOWING BOXES AND SIGNING BELOW TO AUTHORIZE COMPLETION OF THIS ORDER.

- APPROVED WITH NO EXCEPTIONS  
MANUFACTURE PRODUCT AS PER DRAWING
- APPROVED WITH EXCEPTIONS, NO REAPPROVAL  
REQUIRED  
MAKE CHANGES AS NOTED, NO REAPPROVAL DRAWING REQUIRED
- CHANGE AS NOTED, REAPPROVAL REQUIRED  
MAKE CHANGES AS NOTED, SEND CORRECTED DRAWING FOR  
REAPPROVAL BEFORE MANUFACTURE

SIGNATURE: \_\_\_\_\_ DATE: \_\_\_\_\_

- CHANGES REQUEST:
1. \_\_\_\_\_
  2. \_\_\_\_\_
  3. \_\_\_\_\_
  4. \_\_\_\_\_

CAUTION: ONCE THE DRAWING IS APPROVED, JOB CANCELLATION FEES WILL APPLY

PLAN VIEW

CUSTOMER: **NATIONWIDE LIFTS**  
 PROJECT: **LULA - 48 wide x 54 deep**  
 ADDRESS: **Doors Same Side, Rails on Right**  
**888-323-8755 info@elevators.com**

DATE: **06/13/15**  
 REVISION DATE: **06/13/15**  
 COMPLETED BY: **andy.dunne@nwlifts**

OFFICE USE ONLY:  
 CONFIGURATION VERSION STAMP: **0.0**  
 MODULE VERSION STAMP: **D-S-6.7**

Part No. \_\_\_\_\_  
 Variant No. **48415**

**Nationwide Lifts**  
 www.elevators.com

**savaria**

JOB No. \_\_\_\_\_ SHEET No. **1 OF 4**

HALL CALL 1

HALL CALL 2

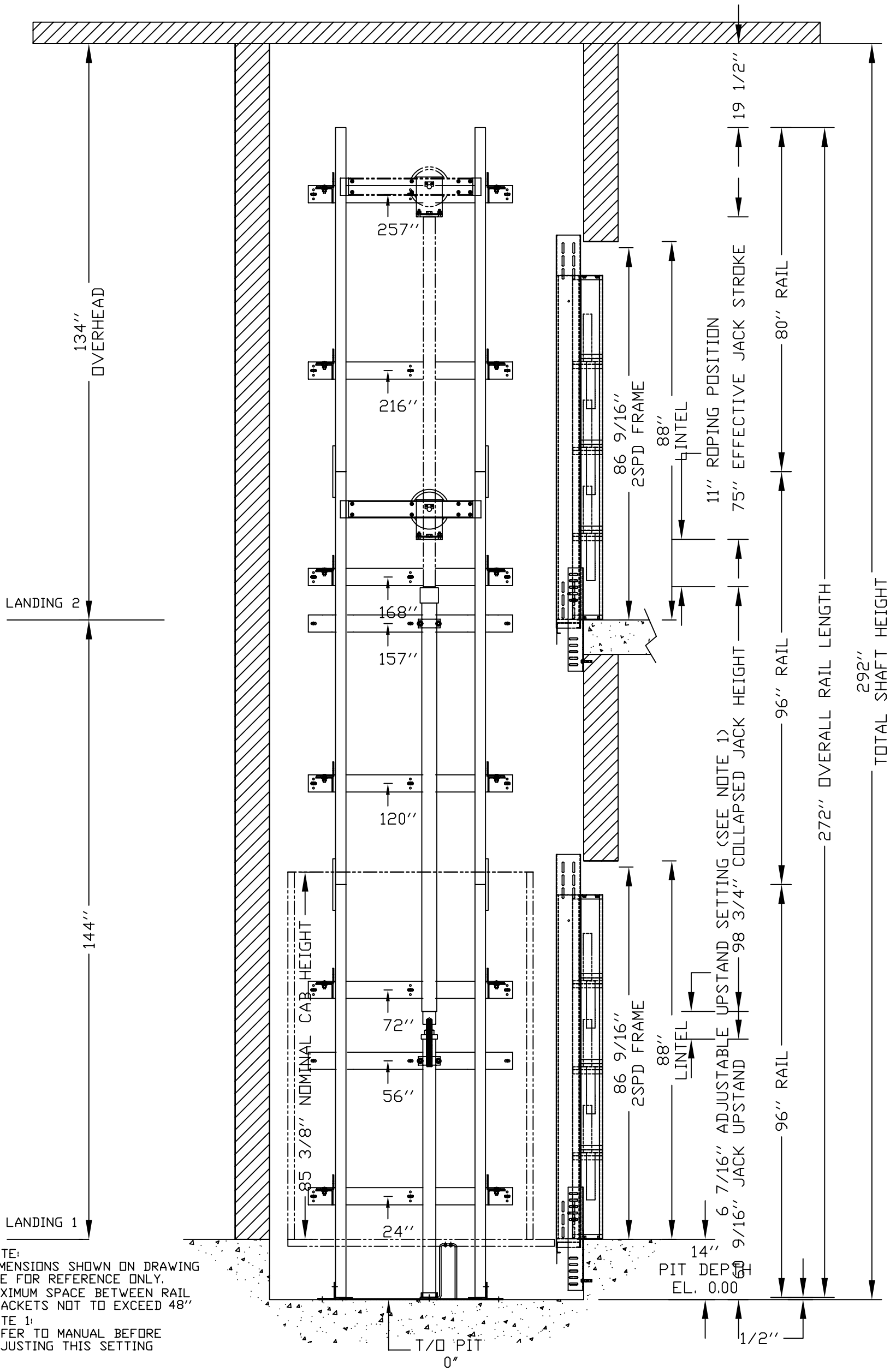
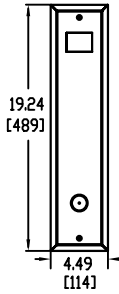
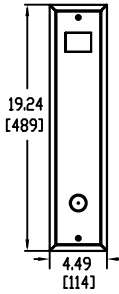

NOTE:  
DIMENSIONS SHOWN ON DRAWING  
ARE FOR REFERENCE ONLY.  
MAXIMUM SPACE BETWEEN RAIL  
BRACKETS NOT TO EXCEED 48"  
NOTE 1:  
REFER TO MANUAL BEFORE  
ADJUSTING THIS SETTING

PIT PROP PROVIDED IN CONFORMANCE TO CLAUSE 5.2.1.4.2

|                              |         |
|------------------------------|---------|
| OFFICE USE ONLY:             |         |
| CONFIGURATION VERSION STAMP: | 0.0     |
| MODULE VERSION STAMP:        | 0-S-6.7 |

|             |       |
|-------------|-------|
| Part No.    |       |
| Variant No. | 48415 |

ELEVATION VIEW B-B

|           |                                 |
|-----------|---------------------------------|
| CUSTOMER: | NATIONWIDE LIFTS                |
| PROJECT:  | LULA - 48 wide x 54 deep        |
| ADDRESS:  | Doors Same Side, Rails on Right |
|           | 888-323-8755 info@elevators.com |

|                |                         |
|----------------|-------------------------|
| DATE:          | 06/13/15                |
| REVISION DATE: | 06/13/15                |
| COMPLETED BY:  | andy.dornley@nlifts.com |

**Nationwide Lifts**  
www.elevators.com

**savaria**

JOB No.

SHEET No. 2 OF 4

# PROVISIONS BY OTHERS

## \*GENERAL

**HOISTWAY-** THE HOISTWAY MUST BE IN ACCORDANCE WITH "SAFETY CODE FOR ELEVATORS AND ESCALATORS" (ASME A17.1) AND ALL STATE AND LOCAL CODES.  
**PLUMB HOISTWAY-** DUE TO CLOSE RUNNING CLEARANCES OWNER/AGENT MUST ENSURE THAT HOISTWAY AND PIT (WHERE PROVIDED) ARE LEVEL, PLUMB AND SQUARE AND ARE IN ACCORDANCE WITH THE DIMENSIONS ON THESE DRAWINGS.

**MINIMUM OVERHEAD CLEARANCE-** OWNER/AGENT MUST ENSURE MINIMUM OVERHEAD CLEARANCE IS IN COMPLIANCE WITH CODES.

**CONSTRUCTION SITE-** OWNER/AGENT TO PROVIDE ALL MASONRY, CARPENTRY AND DRYWALL WORK AS REQUIRED AND SHALL PATCH AND MAKE GOOD (INCLUDING FINISH PAINTING) ALL AREAS WHERE WALLS/FLOORS MAY REQUIRE TO BE CUT, DRILLED OR ALTERED IN ANY WAY TO PERMIT THE PROPER INSTALLATION OF THE LIFT.

## DIMENSIONS

CONTRACTOR/CUSTOMER TO VERIFY ALL DIMENSIONS AND REPORT ANY DISCREPANCIES TO OUR OFFICE IMMEDIATELY.

## \*STRUCTURAL

**FLOOR/SUPPORT WALL LOADS-** STRUCTURE TO ANCHOR A CRANK SHAFT AND SAFETY HARNESS, WHERE APPLICABLE/NEEDED, TO BE PROVIDED BY CONTRACTOR. CONTRACTOR TO ASSURE THAT BUILDING AND SHAFT WILL SAFELY SUPPORT ALL LOADS IMPOSED BY THE LIFT EQUIPMENT. REFER TO THE TABLES ON THIS DRAWING FOR LOADS IMPOSED BY THE EQUIPMENT.

**WHERE DOORS ARE REQUIRED-** SUITABLE LINTELS MUST BE PROVIDED BY OWNER/AGENT. DOOR FRAMES ARE NOT DESIGNED TO SUPPORT OVERHEAD WALL LOADS.

## \*MACHINE ROOM

**LOCATION / ACCESS-** MACHINE ROOM LOCATED AT THE LOWEST LEVEL ADJACENT TO HOISTWAY, UNLESS SHOWN OTHERWISE ON THE LAYOUT DRAWINGS. FIELD ADJUSTMENT BY INSTALLER MAY BE NECESSARY TO MEET JOB SITE CONDITIONS OR REGULATIONS. MACHINE ROOM DOOR IS TO BE LOCKABLE AND IS TO MEET THE REQUIREMENTS OF THE AUTHORITY HAVING JURISDICTION.

**SLEEVES FOR OIL & ELECTRIC LINES-** FROM MACHINE ROOM TO RUNWAY AS REQUIRED. (POSITION PER INSTALLERS INSTRUCTIONS). MINIMUM SCHEDULE 80 PIPING REQUIRED FOR OIL LINES.

|                | DISCONNECT SIZE | TIME DELAY FUSE SIZE | VOLTS    | PHASE       | AMPERAGE  |
|----------------|-----------------|----------------------|----------|-------------|-----------|
| MOTOR & EQUIP. | 30 AMPS         | 30 AMPS              | 208 volt | Three Phase | 15.6 AMPS |
| CAB LIGHTS     | 15 AMPS         | 15 AMPS              | 115 V    | 1           |           |

## \*ELECTRICAL

**POWER SUPPLY-** (SEE SPECIFICATIONS) LOCKABLE FUSED DISCONNECT WITH AUXILIARY CONTACT TO BRAKE THE BATTERY FEED, OR CIRCUIT BREAKERS WITH A 3-POLE BREAKER FOR BATTERY FEED REQUIRED, IN COMPLIANCE WITH ELECTRICAL CODE, AS FOLLOWS:  
 (LOCATED ON WALL ON LOCK JAMB SIDE OF MACHINE ROOM DOOR)

**PERMANENT POWER-** BEFORE INSTALLATION CAN BEGIN, PERMANENT POWER MUST BE SUPPLIED.

**LIGHTING-** THE ILLUMINATION SHALL BE NOT LESS THAN 200 LX (19 FC) AT THE FLOOR LEVEL IN ALL MACHINE ROOMS AND MACHINERY SPACES. ENSURE AT LEAST 100 LX (10 FC) AMBIENT LIGHTING OVER LIFT AREA.

**PHONE-** NEED A DEDICATED PHONE LAND LINE (NOT VoIP) FOR THE PHONE, WHERE APPLICABLE. FOR VoIP PLEASE CONTACT SAVARIA.

## \*ENTRANCES

**FASCIA PANEL BELOW UPPER LEVEL ENTRANCE-** WHERE REQUIRED, FASCIA PANEL MUST BE FASTENED TO A SOLID WALL AND BE PERPENDICULAR TO THE FLOOR AND WALLS. HOISTWAY FASCIA IS NOT SELF-SUPPORTING FOR LONG, CONTINUOUS RUNS VOID OF ENTRANCES. ADEQUATE SUPPORT FOR THE FASCIA MUST BE PROVIDED.

**ENTRANCE ASSEMBLIES-** ENTRANCE ASSEMBLIES MUST BE ADJUSTED TO ALIGN WITH PLATFORM AND INTERLOCK EQUIPMENT. OTHERS TO ALLOW AN ADEQUATE ROUGH OPENING.

**RETURN WALLS-** RETURN WALLS AT ENTRANCES MUST BE BUILT-IN BY OTHERS AFTER ENTRANCE ASSEMBLIES ARE IN PLACE. ENTRANCE ASSEMBLY MUST BE SECURELY FASTENED TO WALLS BY ELEVATOR CONTRACTOR.

# SPECIFICATIONS

## GENERAL

CLASSIFICATION: \_\_\_\_\_ Public Building  
 APPLIED CODE: \_\_\_\_\_ CSA/ASMEA17.1/B44-2010 Sec 5.2  
 MODEL: \_\_\_\_\_ Orion  
 CAPACITY: \_\_\_\_\_ 1400lbs  
 NOMINAL SPEED: \_\_\_\_\_ 30 fpm  
 TRAVEL: \_\_\_\_\_ 144 "  
 PIT DEPTH: \_\_\_\_\_ 14 "  
 POWER SUPPLY: \_\_\_\_\_ 60 Hz Three Phase 208 volt

## HYDRAULIC

PUMP MFR. \_\_\_\_\_ CONCORD  
 PUMP MODEL: \_\_\_\_\_ VICKERS 3P  
 MOTOR: \_\_\_\_\_ 5.0 hp  
 VALVE MODEL NO. \_\_\_\_\_ EPV - 7  
 VALVE COIL VOLTS: \_\_\_\_\_ 24 V DC  
 MAX WORKING PRESSURE: \_\_\_\_\_ 1500 psi (10340 kPa)  
 RELIEF VALVE SETTING: \_\_\_\_\_ MAX 25% ABOVE ACTUAL WORKING PRESSURE  
 RESERVOIR: \_\_\_\_\_ 22 Gal.  
 HOSE & SAFETY VALVE: \_\_\_\_\_ no

## CAR FINISH DETAILS

CAB PANEL SELECTION: \_\_\_\_\_ White Steel Colour  
 CEILING SELECTION: \_\_\_\_\_ standard (white)  
 CAB ENTRANCE: \_\_\_\_\_ Match Cab  
 PLASTIC LAMINATE FINISHES \_\_\_\_\_ Not Applicable  
 POT LIGHT FINISH: \_\_\_\_\_ Stainless Steel  
 TRIM COLOUR: \_\_\_\_\_ Not Applicable  
 CAR STATION PLATE: \_\_\_\_\_ stainless steel  
 HAND RAIL TYPE: \_\_\_\_\_ Stainless Steel Cylindrical  
 CAB FLOORING: \_\_\_\_\_ Plywood Floor  
 FINISHED FLOOR THICKNESS: \_\_\_\_\_ 3/8" finish  
 TELEPHONE BOX: \_\_\_\_\_ no  
 TELEPHONE BOX FINISH: \_\_\_\_\_ Not Applicable  
 HAND FREE PHONE: \_\_\_\_\_ yes, with phone line monitoring

## CAR DIMENSIONS/PLATFORM GATES

CAB TYPE: \_\_\_\_\_ Type 1 Right Hand  
 CAB HEIGHT: \_\_\_\_\_ 84" Standard Cab Height  
 CAB OPERATION: \_\_\_\_\_ automatic operation  
 GATES REQUIRED: \_\_\_\_\_ Automatic Operated Gates  
 GATE TYPE: \_\_\_\_\_ 2 Spd Doors (Wittur) match CAB  
 GATE FINISH: \_\_\_\_\_ Baked Enamel White  
 INSIDE PLATFORM AREA: \_\_\_\_\_ 18 sf.

## HOISTWAY

DOOR TYPE: \_\_\_\_\_ 2 spd Sliding Doors (Wittur)  
 HOISTWAY DOORS FINISH: \_\_\_\_\_ Standard Finish (Primer Grey)  
 HOISTWAY FINISH: \_\_\_\_\_ Masonary

## JACK UNIT

EFFECTIVE STROKE: \_\_\_\_\_ 75"  
 SOLID PLUNGER O/D: \_\_\_\_\_ 2 3/4 "  
 CYLINDER O/D: \_\_\_\_\_ 3 1/2 "  
 CYLINDER I/D: \_\_\_\_\_ 3 "  
 SPLIT CYLINDER? \_\_\_\_\_ no  
 COLLAPSED LENGTH: \_\_\_\_\_ 98 3/4 "  
 CYLINDER WALL THICKNESS: \_\_\_\_\_ 1/4 "

## SUSPENSION

TYPE: \_\_\_\_\_ AIRCRAFT CABLE 2 X 3/8" DIA.  
 CONSTRUCTION: \_\_\_\_\_ IWRC 7 X 19, GALVANIZED STEEL RHRL  
 NOMINAL STRENGTH: \_\_\_\_\_ 14,400 lbs Per Cable  
 SPECS: \_\_\_\_\_ MI-DTL-83420

## OVER SPEED VALVE

MODEL: \_\_\_\_\_ AS PER SECTION 3.19.4.7  
 BLAIN R10 AA  
 (1500psi (10340 kPa) MAX WORKING PRESSURE)

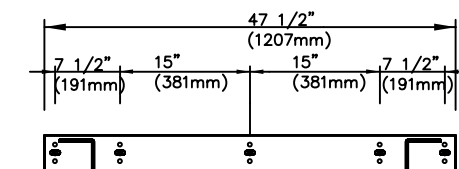
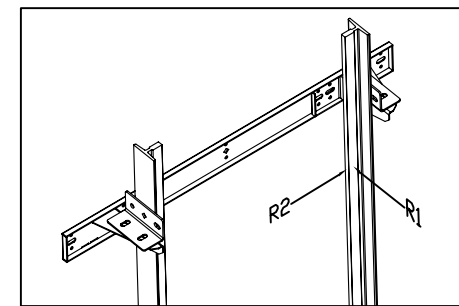

RAIL BRACKET

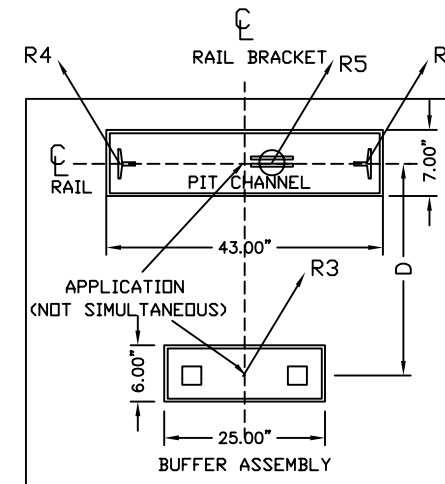

| CAB WIDTH | DIST (D) |
|-----------|----------|
| 42'       | 26.75'   |
| 48'       | 30.75'   |
| 51'       | 33.75'   |
| 54'       | 36.75'   |

| PIT RE-ACTION FORCE |          |
|---------------------|----------|
| R3                  | 8000 LBS |
| R4                  | 3000 LBS |
| R5                  | 9000 LBS |

| RAIL FORCES               |         |
|---------------------------|---------|
| *R1                       | *R2     |
| 720 lbf                   | 260 lbf |
| RAIL WEIGHT: 8.0 lbs / ft |         |

FOR TOTAL PULL-OUT FORCE ON RAIL BRACKET, R1 MUST BE DOUBLED eg. 2 x 720 = 1440 lbf

FOR LOCAL APPLICATION OF PIT LOAD, SEE PIT CHANNEL/BUFFER SKETCH.

## FIRST DOOR BY LANDING CHART

|                      | LANDING 1      | LANDING 2                      |
|----------------------|----------------|--------------------------------|
|                      | DOOR TYPE      | 2 Speed Sliding Doors (Wittur) |
| ENTRANCE SIDE        | Side C         | Side C                         |
| DOOR LATCH           | Left Hand      | Left Hand                      |
| LOCK TYPE            | Not Applicable | Not Applicable                 |
| AUTO DOOR OPENER     | None           | None                           |
| HALL CALL KEY SWITCH | Keyless        | Keyless                        |
| HOISTWAY ACCESS      |                | yes                            |
| FLOOR MARKING        | 1              | 2                              |
| MAIN EGRESS FLOOR    | 1              |                                |

## OPTIONS

FASTENERS: \_\_\_\_\_ Concrete Anchors  
 FIREMAN'S SERVICE: \_\_\_\_\_ Fireman Service  
 OVERSPEED GOV./VALVE: \_\_\_\_\_ OverSpeed Valve  
 CONDUCTOR CABLE: \_\_\_\_\_ 40' cable  
 DATA ACCESS TERMINAL: \_\_\_\_\_ No DAT  
 DUPLINE PROGRAMMING TOOL: \_\_\_\_\_ Programmer not Included  
 TEMP. RUN BUTTON: \_\_\_\_\_ Temp Run Button not included  
 SPEEDY SET-UP JIG: \_\_\_\_\_ Speedy Jig Not required

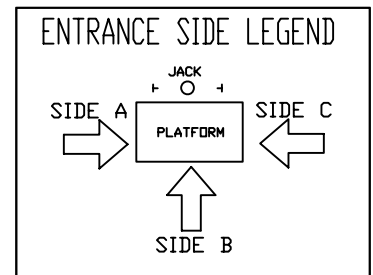

## OFFICE USE ONLY:

CONFIGURATION VERSION STAMP: 0.0  
 MODULE VERSION STAMP: 0-S-6.7

Part No. \_\_\_\_\_  
 Variant No. 48415

**Nationwide Lifts**  
 www.elevators.com

**savaria**

JOB No. \_\_\_\_\_ SHEET No. 3 OF 4

CUSTOMER: \_\_\_\_\_  
**NATIONWIDE LIFTS**  
 PROJECT: LULA - 48 wide x 54 deep  
 ADDRESS: Doors Same Side, Rails on Right  
 888-323-8755 info@elevators.com

DATE: 06/13/15  
 REVISION DATE: 06/13/15  
 COMPLETED BY: andy.dumble@nlifts.com

Data Sheet  
 LIMITED USE LIMITED APPLICATION

| REVISIONS |           |            |              |
|-----------|-----------|------------|--------------|
| REV       | ECD NO.   | DATE       | REVISED BY   |
| 000       | 07 - 0023 | 12/03/2007 | 1 ST RELEASE |
| 001       |           | 04/05/2010 | ALEXANDRE B  |

NOTE: ENTRANCE FRAME ASSEMBLY IS NOT DESIGN TO BEAR OVERHEAD LOADS. CONTRACTOR TO PROVIDE ADEQUATE WALL STRUCTURE SUPPORT.

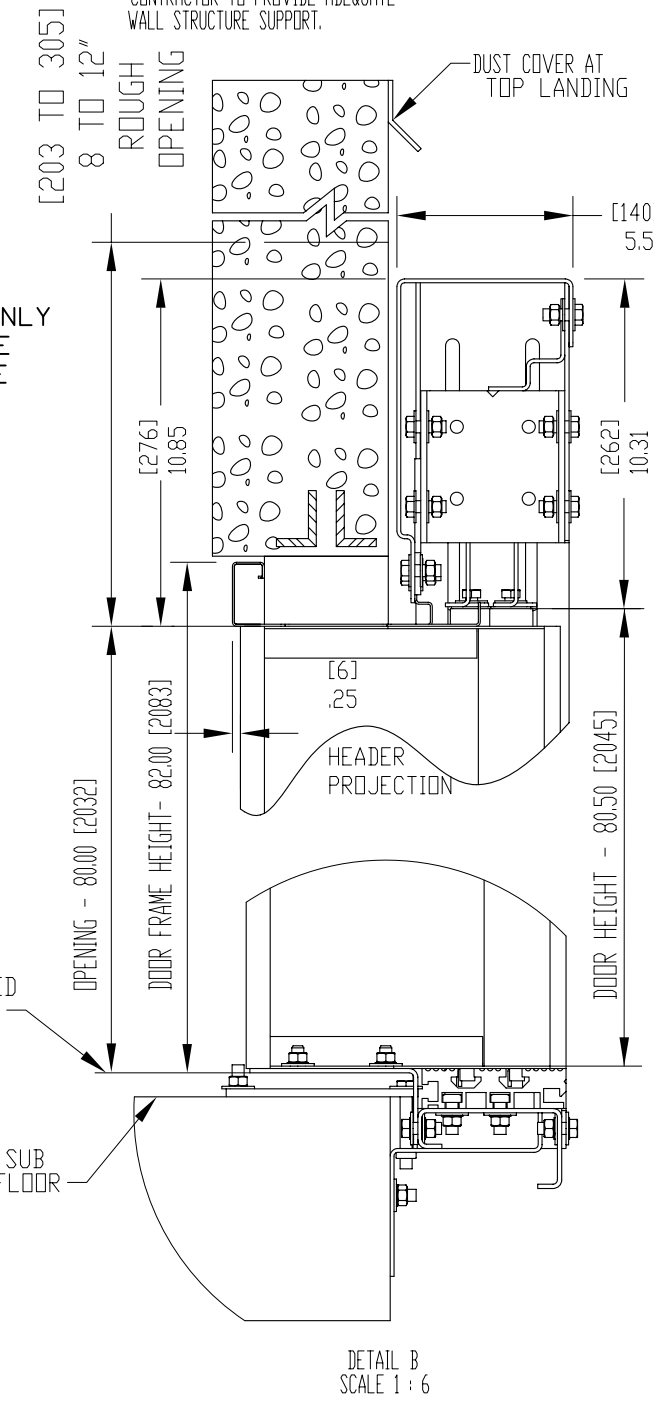
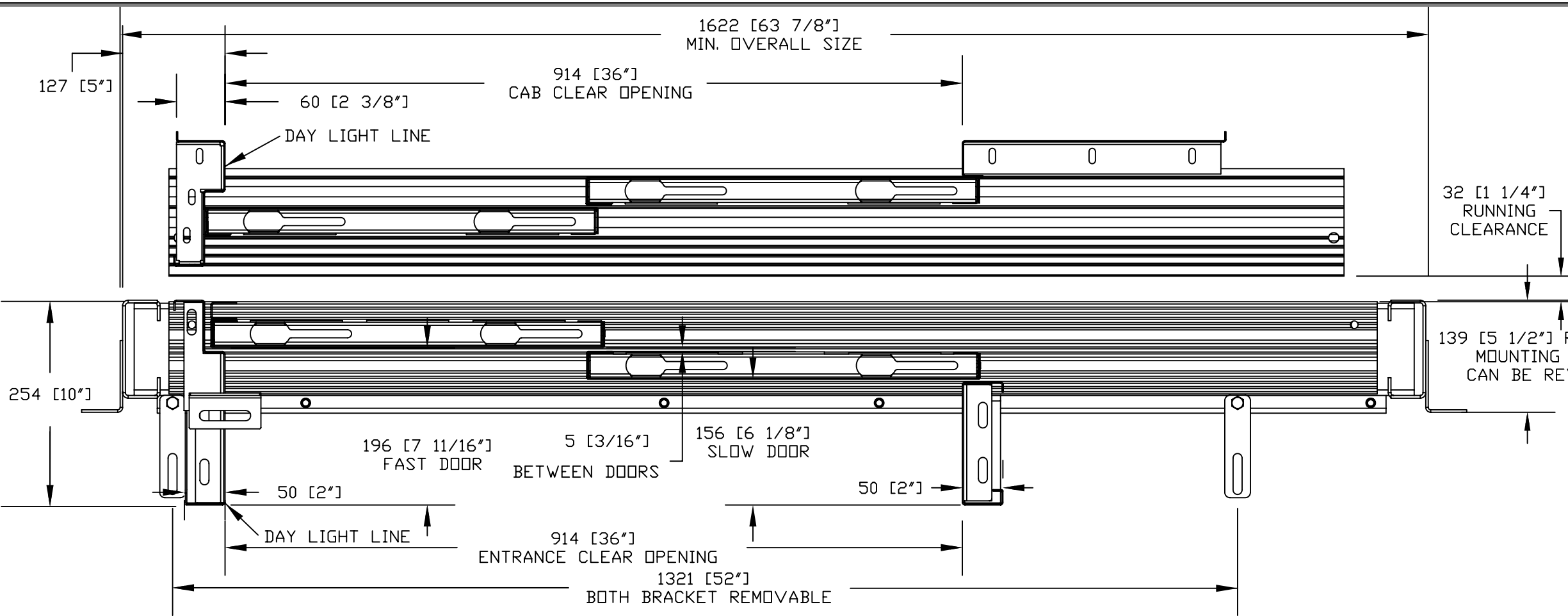

ENTRANCE LOADS ON BUILDING  
 RH = 5000 N (1125 lbf)  
 RVD = 1550 N (350 lbf)  
 RVU = 1000 N (225 lbf)  
 PER SECTION 2.11.11.8.

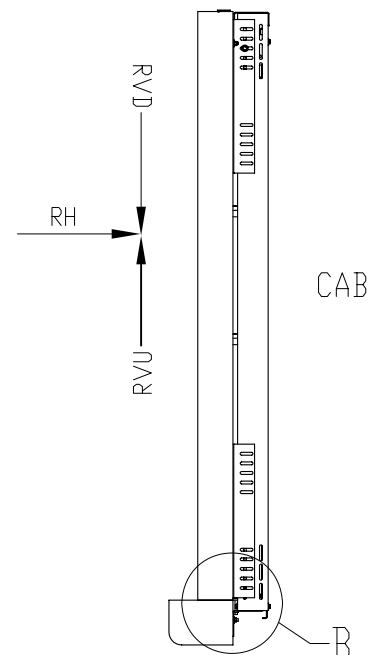
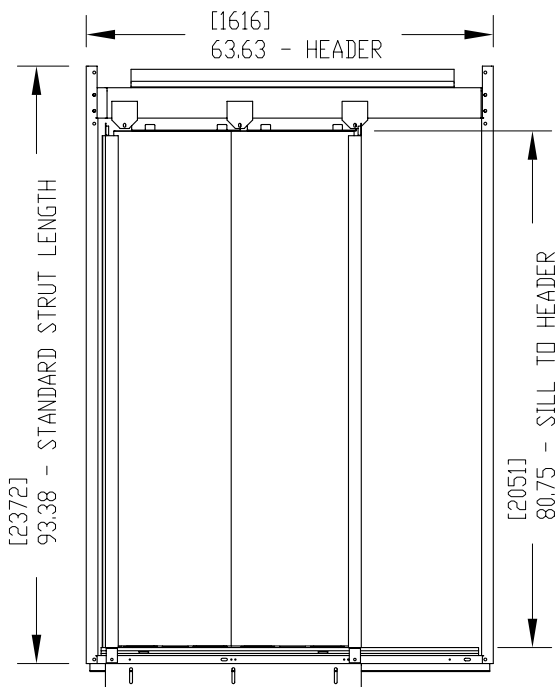
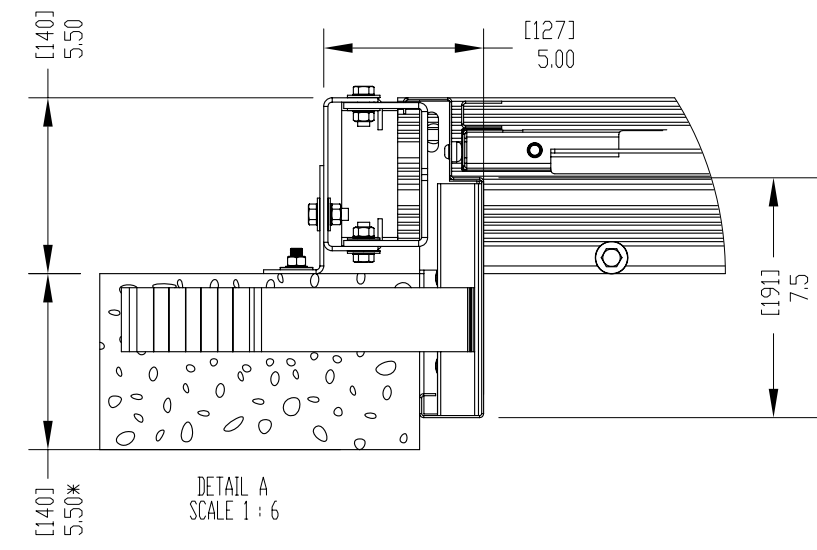
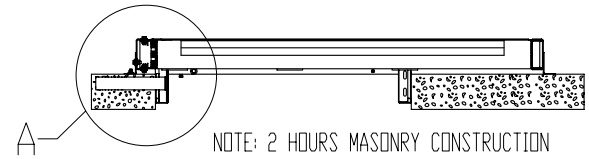

LEFT HAND SHOWN

LANDING 2 SP. DOOR ASSEMBLY  
 MASONRY CONSTRUCTION 36 X 80

| OFFICE USE ONLY:             |         |
|------------------------------|---------|
| CONFIGURATION VERSION STAMP: | 0.0     |
| MODULE VERSION STAMP:        | 0-S-6.7 |

CUSTOMER: NATIONWIDE LIFTS  
 PROJECT: LULA - 48 wide x 54 deep  
 ADDRESS: Doors Same Side, Rails on Right  
 888-323-8755 info@elevators.com

DATE: 06/13/15  
 REVISION DATE: 06/13/15  
 COMPLETED BY: andy.dumley@nllifts

Part No. Variant No. 48415

**Nationwide Lifts**  
www.elevators.com

**savaria**

JOB No. SHEET No. 4 OF 4